



Report No.: 140415039GZU-003
Issued: 03 September 2014

TEST REPORT

Applicant Name & Address : GUANGDONG BE-TECH SECURITY SYSTEMS LIMITED.
No. 17, Keyuan 3 Road, Ronggui, Shunde High-Tech Zone, Foshan,
Guangdong, P.R.China

Manufacturing Site : Same as applicant

Sample Description
Product : Elevator Controller
Model No. : DTM
Electrical Rating : 100-240V, 50/60Hz

Date Received : 15 April 2014

Date Test Conducted : 13 August 2014 - 26 August 2014

Test standards : ETSI EN 301 489-3 V1.6.1
ETS I EN 301 489-1 V1.9.2

Test Result : Pass

Conclusion : The submitted samples complied with the above EMC standards.

Remark : None.

*****End of Page*****

Prepared and Checked By:

Approved By:

Helen Ma
Helen Ma
Sr.Project Engineer
Intertek Guangzhou

Strong Yao Signature
Strong Yao
Asst. Technical Manager
Intertek Guangzhou
03 September 2014 Date

This report is for the exclusive use of Intertek's Client and is provided pursuant to the agreement between Intertek and its Client. Intertek's responsibility and liability are limited to the terms and conditions of the agreement. Intertek assumes no liability to any party, other than to the Client in accordance with the agreement, for any loss, expense or damage occasioned by the use of this report. Only the Client is authorized to permit copying or distribution of this report and then only in its entirety. Any use of the Intertek name or one of its marks for the sale or advertisement of the tested material, product or service must first be approved in writing by Intertek. The observations and test results in this report are relevant only to the sample tested. This report by itself does not imply that the material, product, or service is or has ever been under an Intertek certification program. The test report only allows to be revised within three years from its original issued date unless further standard or the requirement was noticed.

Intertek Testing Services Shenzhen Ltd. Guangzhou Branch
Block E, No.7-2 Guang Dong Software Science Park, Caipin Road, Guangzhou Science City, GETDD Guangzhou, China
Tel / Fax: 86-20-8213 9688/86-20-3205 7538

CONTENT

TEST REPORT	1
CONTENT	2
1 TEST RESULTS SUMMARY	4
2 EMC RESULTS CONCLUSION	5
3 LABORATORY MEASUREMENTS	6
4 EMC REQUIREMENTS SPECIFICATION IN EN 301 489-3	7
5 EMI TEST	8
5.1 CONTINUOUS CONDUCTED DISTURBANCE VOLTAGE TEST	8
5.1.1 Used Test Equipment	8
5.1.2 Block Diagram of Test Setup	8
5.1.3 Test Setup and Procedure	8
5.1.4 Test Data	10
5.1.5 Emission Curve	11
5.1.6 Measurement Uncertainty	12
5.2 RADIATED DISTURBANCE	12
5.2.1 Used Test Equipment	12
5.2.2 Block Diagram of Test Setup	12
5.2.3 Test Setup and Procedure	13
5.2.4 Test Data	13
5.2.5 Test Curve	14
5.2.6 Measurement uncertainty	15
6 HARMONIC OF CURRENT	15
7 FLICKER	15
8 EMS TEST	16
8.1 ELECTROSTATIC DISCHARGE IMMUNITY	18
8.1.1 Used Test Equipment	18
8.1.2 Block Diagram of Test Setup	19
8.1.3 Test Setup and Procedure	19
8.1.4 Test Result	21
8.2 RADIATED ELECTROMAGNETIC FIELD IMMUNITY	22
8.2.1 Used Test Equipment	22
8.2.2 Block Diagram of Test Setup	23
8.2.3 Test Setup and Procedure	24
8.2.4 Test Result	24
8.3 ELECTRICAL FAST TRANSIENT/BURST	25
8.3.1 Used Test Equipment	25
8.3.2 Block Diagram of Test Setup	25
8.3.3 Test Setup and Procedure	26
8.3.4 Test Result	26
8.4 SURGE IMMUNITY	27
8.4.1 Used Test Equipment	27
8.4.2 Block Diagram of Test Setup	27
8.4.3 Test Setup and Procedure	27
8.4.4 Test Result	28
8.5 INJECTED CURRENT	29
8.5.1 Used Test Equipment	29



Report No.: 140415039GZU-003
Issued: 03 September 2014

8.5.2	<i>Block Diagram of Test Setup</i>	29
8.5.3	<i>Test Setup and Procedure</i>	29
8.5.4	<i>Test Result</i>	30
8.6	VOLTAGE DIPS AND INTERRUPTIONS	31
8.6.1	<i>Used Test Equipment</i>	31
8.6.2	<i>Block Diagram of Test Setup</i>	31
8.6.3	<i>Test Setup and Procedure</i>	31
8.6.4	<i>Test Result</i>	32
9	APPENDIX I - PHOTOS OF TEST SETUP	33
10	APPENDIX II - PHOTOS OF EUT	36

1 **TEST RESULTS SUMMARY**

Test Item	Standard and Clause Number		Result
	ETSI EN 301 489-3	ETSI EN 301 489-1	
Continuous conducted disturbance voltage	7.1	8.4	Pass
Radiated disturbance	7.1	8.2	Pass
Harmonic of current	7.1	8.5	Pass
Flicker	7.1	8.6	Pass
ESD immunity	7.2	9.3	Pass
Radiated EM field immunity	7.2	9.2	Pass
EFT immunity	7.2	9.4	Pass
Surge immunity	7.2	9.8	Pass
Inject current immunity	7.2	9.5	Pass
Voltage dips and interruption immunity	7.2	9.7	Pass

Remark: 1. When determining the test results, measurement uncertainty of tests has been considered.

EMC Results Conclusion
(with Justification)

RE: Testing Pursuant to R&TTE Directive 1999/5/EC Performed on the Elevator Controller,
Model: DTM.

We tested the Elevator Controller, Model: DTM, to determine if it was in compliance with the relevant EN standards as marked on the Test Results Summary. We found that the unit met the requirements of ETSI EN 301 489-3, ETSI EN 301 489-1 standards when tested as received. The worst case's test data was presented in this test report.

The production units are required to conform to the initial sample as received when the units are placed on the market.

3 LABORATORY MEASUREMENTS

Configuration Information

Equipment Under Test (EUT):	Elevator Controller
Model:	DTM
Serial No.	Not Labeled
Support Equipment:	N/A
Rated Voltage:	100-240V, 50/60Hz
Condition of Environment:	Temperature : 22~28°C Relative Humidity: 35~60% Atmosphere Pressure 86~106kPa

Notes:

1. The EMI measurements had been made in the operating mode produced the largest emission in the frequency band being investigated consistent with normal applications. An attempt had been made to maximize the emission by varying the configuration of the EUT.
2. The EMS measurements had been made in the frequency bands being investigated, with the EUT in the most susceptible operating mode consistent with normal applications. The configuration of the test sample had been varied to achieve maximum susceptibility.

4 EMC Requirements Specification in EN 301 489-3

Type of SRD Equipment in EN 301 489-3, subclause 4.1 table 1

Primary Function Type	Technical nature of the primary function
I	Transfer of messages (digital or analogue signals)
II	Transfer of audio (speech or music)
III	Others

Classification of SRD Equipment in EN 301 489-3, subclause 6.1 table 3

Device Type	Risk assessment of communication link performance
1	Highly reliable SRD communication media; e.g. serving human life inherent system (may result in a physical risk to a person).
2	Medium reliable SRD communication media; e.g. causing inconvenience to persons, which cannot simply overcome by other means
3	Standard reliable SRD communication media; e.g. causing inconvenience to persons, which can simply overcome by other means (e.g. manual)

Remark: The EUT belong to Type I, class 3.

5 EMI TEST

Special conditions for EMC emission measurements EN 301 489-3 table 5

Reference to clauses in EN 301 489-1	Special product-related conditions, additional to or modifying the test conditions in EN 301 489-1, clause 8
8.3.2 and 8.4.2: Test method; DC power input/output ports, and AC mains input/output ports	Attention: The exclusion band for transmitters shall be considered for transmitters operating at frequencies below 30 MHz (see clause 4.3.2).

5.1 Continuous Conducted Disturbance Voltage Test

Basic Standard :	EN 55022: 2006 + A1: 2007
Classification :	Class B
Port :	AC mains input ports

5.1.1 Used Test Equipment

Equipment No.	Equipment	Model	Manufacturer
EM080-05	EMI receiver	ESCI	R&S
EM006-05	LISN	ENV216	R&S
EM004-04	EMC shield Room	8m×3m×3m	Zhongyu

5.1.2 Block Diagram of Test Setup

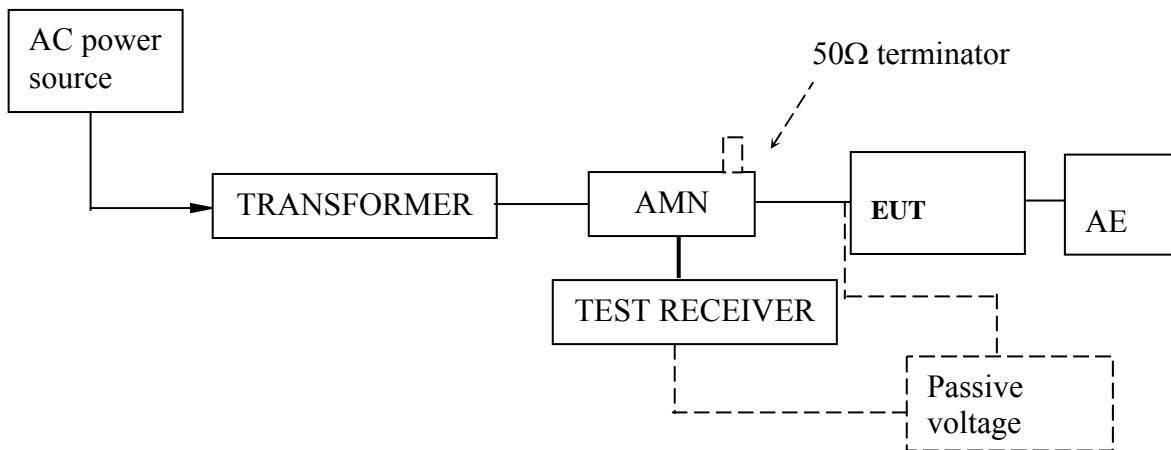

5.1.3 Test Setup and Procedure

The EUT was set to achieve the maximum emission level. The mains terminal disturbance voltage was measured with the EUT in a shielded room. The EUT was connected to AC power source through an Artificial Mains Network which provides a 50Ω linear impedance. An Artificial hand is used if appropriate (for handheld apparatus). The load/control terminal disturbance voltage was measured with a passive voltage probe if appropriate.

The table-top EUT was placed on a 0.4m high non-metallic table above earthed ground plane(Ground Reference Plane).And for floor standing EUT, was placed on a 0.1m high non-metallic supported on GRP. The EUT keeps a distance of at least 0.8m from any other of the metallic surface. The Artificial Mains Network is situated at a distance of 0.8m from the EUT.

During the test, mains lead of EUT excess 0.8m was folded back and forth parallel to the lead so as to form a horizontal bundle with a length between 0.3m and 0.4m.

The bandwidth of test receiver was set at 9 kHz. The frequency range from 150 kHz to 30MHz was checked.

When measurements of disturbance are being made, the appliance shall be operated under the conditions defined in clause 7.

5.1.4 Test Data

At main terminal: Pass

Tested Wire: Live

Operation Mode: on mode

EDIT PEAK LIST (Final Measurement Results)				
Trace1:	CE22QP			
Trace2:	CE22AV			
Trace3:	---			
TRACE	FREQUENCY	LEVEL dBµV		DELTA LIMIT dB
2 Average	22.586 MHz	43.73	L1	-6.26
1 Quasi Peak	22.474 MHz	49.52	L1	-10.47
1 Quasi Peak	162 kHz	54.02	L1	-11.33
2 Average	17.39 MHz	34.50	L1	-15.49
1 Quasi Peak	270 kHz	44.91	L1	-16.20
2 Average	162 kHz	37.82	L1	-17.54
2 Average	9.982 MHz	31.16	L1	-18.83
2 Average	4.838 MHz	26.87	L1	-19.12
2 Average	270 kHz	31.38	L1	-19.73
1 Quasi Peak	17.274 MHz	38.81	L1	-21.18
1 Quasi Peak	10.018 MHz	36.30	L1	-23.69
2 Average	1.978 MHz	22.13	L1	-23.86
2 Average	2.574 MHz	21.97	L1	-24.03
1 Quasi Peak	4.902 MHz	31.81	L1	-24.18

Tested Wire: Neutral

Operation Mode: EUT on

EDIT PEAK LIST (Final Measurement Results)				
Trace1:	CE22QP			
Trace2:	CE22AV			
Trace3:	---			
TRACE	FREQUENCY	LEVEL dBµV		DELTA LIMIT dB
2 Average	23.302 MHz	42.60	L1	-7.39
1 Quasi Peak	22.594 MHz	48.68	L1	-11.31
2 Average	21.538 MHz	35.27	L1	-14.72
1 Quasi Peak	21.474 MHz	42.66	L1	-17.34
1 Quasi Peak	218 kHz	45.40	L1	-17.49
1 Quasi Peak	166 kHz	47.53	L1	-17.61
2 Average	162 kHz	36.58	L1	-18.78
1 Quasi Peak	298 kHz	39.95	L1	-20.33
1 Quasi Peak	13.426 MHz	31.70	L1	-28.29

5.1.5 Emission Curve
At mains terminal:
Tested Wire: Live

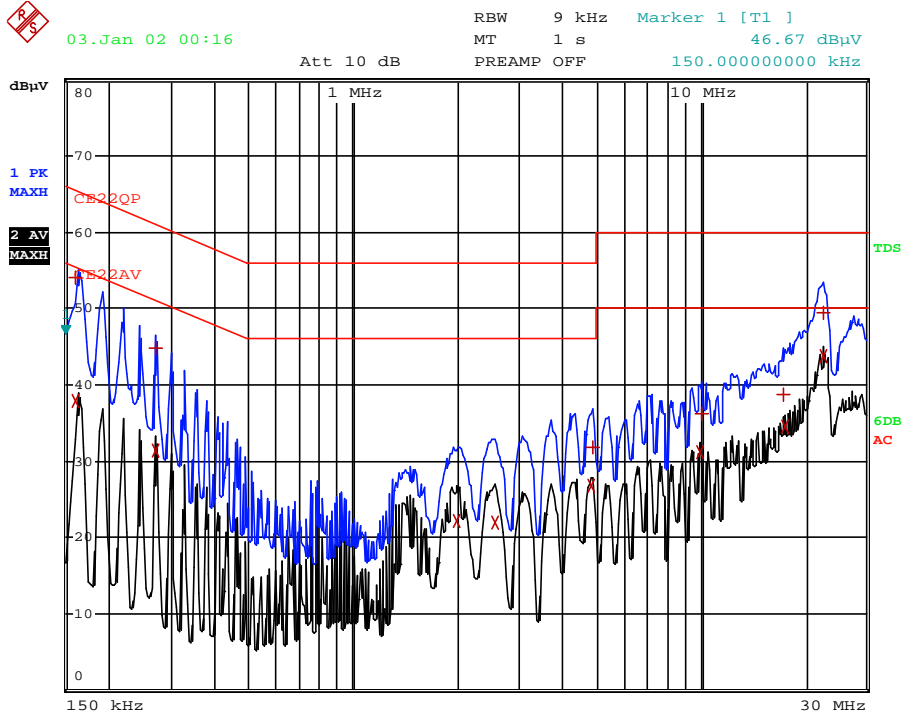

Tested Wire: Neutral

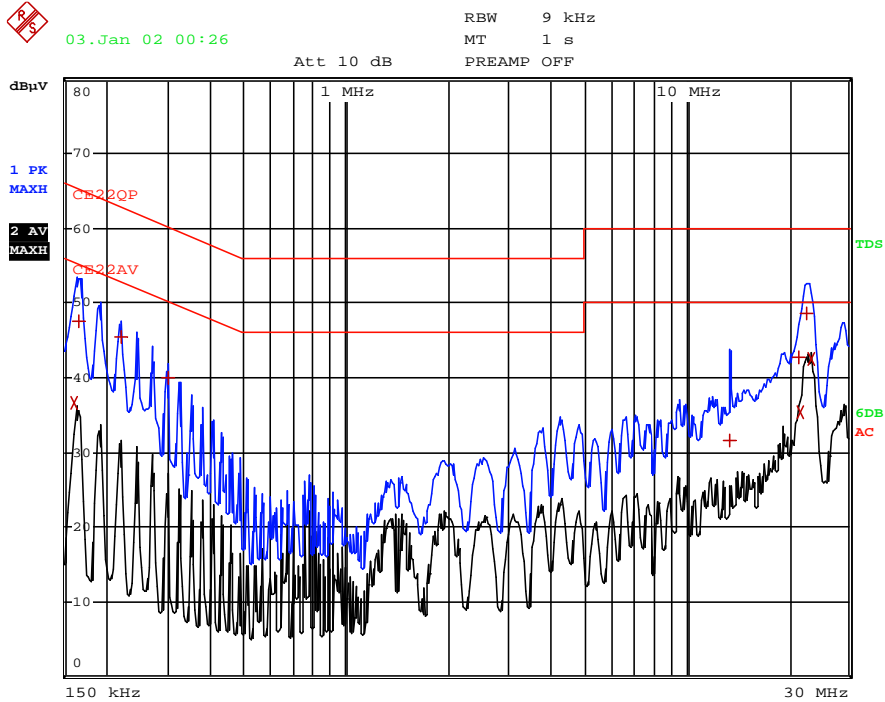

5.1.6 Measurement Uncertainty

The measurement uncertainty describes the overall uncertainty of the given measured value during the operation of the EUT.

Measurement uncertainty is calculated in accordance with CISPR 16-4-2: 2003.

Measurement uncertainty of mains terminal disturbance voltage in CISPR band B: 2.58 dB.

The measurement uncertainty is given with a confidence of 95%, $k=2$.

5.2 Radiated Disturbance

Test Result: Pass

Basic Standard :	EN 55022: 2006 + A1: 2007
Classification :	Class B
Port :	Enclosure Port of Ancillary Equipment

5.2.1 Used Test Equipment

Equip. No.	Equipment	Model	Manufacturer
EM030-01	3m Semi-Anechoic Chamber	9×6×6 m3	ETS•LINDGREN
EM030-02	Control room for 3m Semi-Anechoic Chamber	4×4×3 m3	ETS•LINDGREN
EM031-02	EMI Test Receiver (9 kHz~7 GHz)	R&S ESR7	R&S
EM061-03	TRILOG Super Broadband test Antenna (30 MHz-1.5 GHz)	VULB 9161	SCHWARZBECK
EM031-02-01	Coaxial cable	/	R&S

5.2.2 Block Diagram of Test Setup

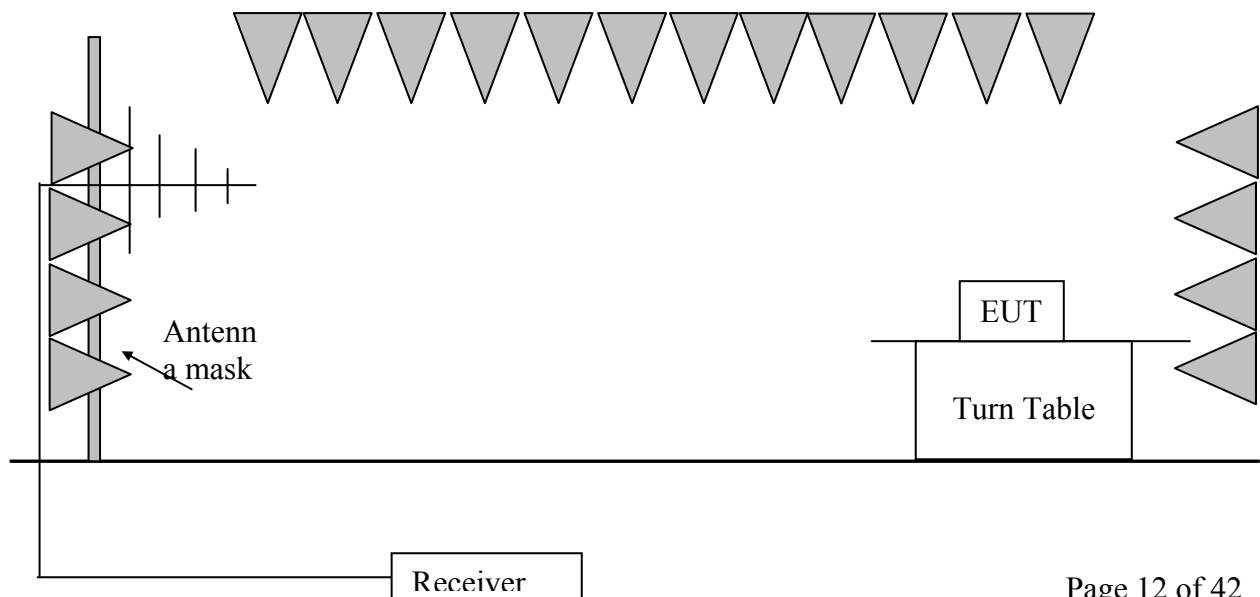

5.2.3 Test Setup and Procedure

The measurement was applied in a semi-anechoic chamber (SAC). Table-top equipment is placed on a non-conductive setup table with height 0,8 m ± 0,01 m above the ground plane. Floor-standing equipment is placed on a non-conductive support at a height of 5 cm to 15 cm above the ground plane. The turn table rotated 360 degrees to determine the position of the maximum emission level. The EUT was set 3 meters away from the receiving antenna which was mounted on an antenna mask. The antenna moved up and down between from 1 meter to 4 meters to find out the maximum emission level.

Broadband antenna was used as receiving antenna. Both horizontal and vertical polarization of the antenna was set on measurement. In order to find the maximum emission, all of the interface cables were manipulated during radiated test.

The bandwidth setting on R&S Test Receiver was 120 kHz.

The frequency range from 30 MHz to 1000 MHz was checked

5.2.4 Test Data

Test Mode: on mode

Antenna Polarization	Frequency [MHz]	Measured Net at 3m [dB(μV/m)]	Limit at 3m [dB(μV/m)]
Horizontal	200.0	< 30.0	40.0
Horizontal	400.0	< 37.0	47.0
Horizontal	800.0	< 37.0	47.0
Vertical	32.0	33.6	40.0
Vertical	40.0	30.4	40.0
Vertical	44.0	30.1	40.0

5.2.5 Test Curve

H:

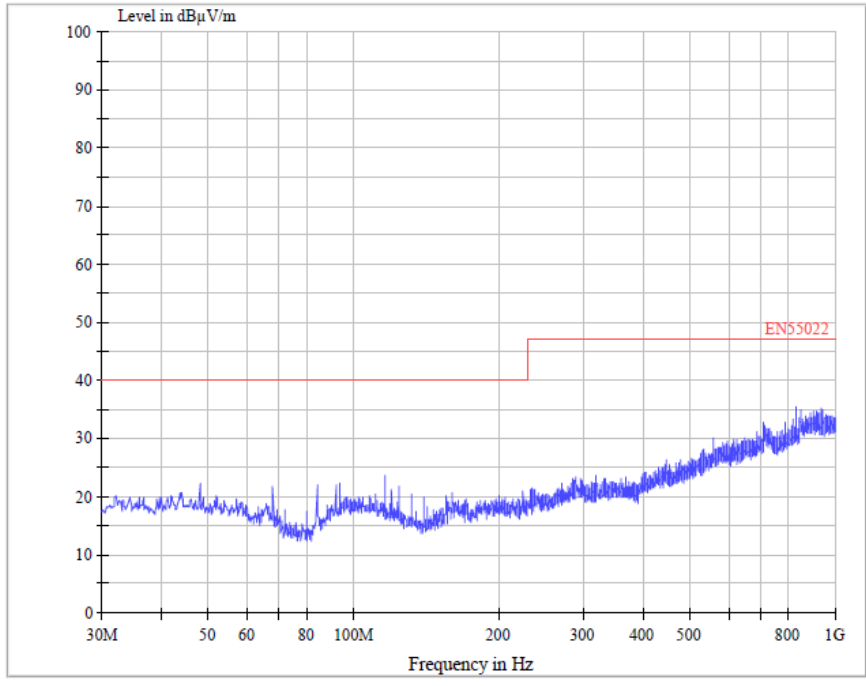

V:

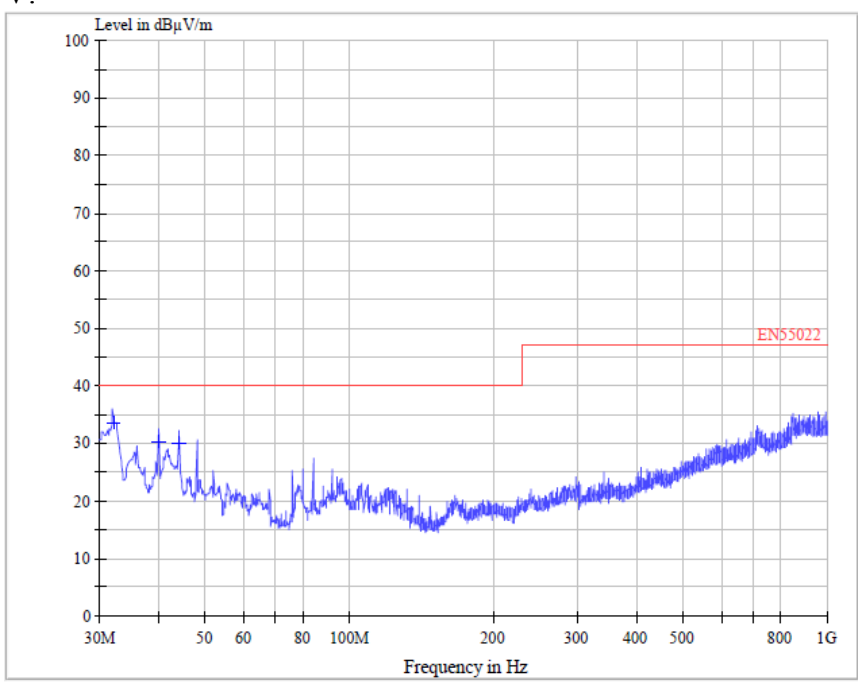

5.2.6 Measurement uncertainty

The measurement uncertainty describes the overall uncertainty of the given measured value during the operation of the EUT.

Measurement uncertainty is calculated in accordance with CISPR 16-4-2:2003.

Measurement uncertainty of radiated emission: 4.87 dB.

The measurement uncertainty is given with a confidence of 95%, $k=2$.

6 Harmonic of Current

Test Result: Pass

Remark: This product is not defined as lighting equipment, and rated power is less than 75W, therefore, no limit applies according to EN 61000-3-2.

7 Flicker

Test Result: Pass

Remark: This product is unlikely to produce voltage flicker or fluctuation, so no flicker test was performed on the product.

8 EMS TEST

Reference to clauses in EN 301 489-1	Special product-related conditions, additional to or modifying the test conditions in EN 301 489-1, clause 9
9.2.2: Test method; Radio frequency electromagnetic field	<p>Attention:</p> <p>The width of the steps for the test frequency increments is device type dependent:</p> <ul style="list-style-type: none"> • for f device type 1 or device type2, the stepped frequency increments shall be 1 % of the momentary used test frequency; • for device type3, the stepped frequency increments shall be 10 % of the momentary used test frequency.
9.5.2: Test method; Radio frequency, common mode	<p>Attention:</p> <p>The width of the steps for the test frequency increments is device typedependent:</p> <ul style="list-style-type: none"> • for device type1 or device type2, the stepped frequency increments shall be 1 % of the momentary used test frequency in the frequency range 5 MHz to 80 MHz; • for device type3, the stepped frequency increments shall be 10 % of the momentary used test frequency in the frequency range 5 MHz to 80 MHz.
9.7.3: Performance criteria; Voltage dips and interruptions	<p>Attention:</p> <p>The performance criteria are device typedependent:</p> <p>For a voltage dip corresponding to a reduction of the supply voltage of 30 % for 10 ms the performance criteria CT or CR specified in clauses 6.4 or 6.6 shall apply as appropriate.</p> <p>For a voltage dip corresponding to a reduction of the supply voltage of 60 % for 100 ms the following class-dependent performance criteria shall apply:</p> <ul style="list-style-type: none"> • for transmitters, belonging to device type1, the performance criteria CT (see clause 6.4); • for transmitters, belonging to device type2 or 3, the performance criteria TT (see clause 6.5); • for receivers, belonging to device type1, the performance criteria CR (see clause 6.6); • for receivers, belonging to device type2 or 3, the performance criteria TR (see clause 6.7). <p>For a voltage interruption corresponding to a reduction of the supply voltage of > 95 % for 5 000 ms the performance criteria TT or TR specified in clauses 6.5 or 6.7 shall apply as appropriate.</p>

Performance Criteria of EN 301 489-3, subclause 6.3 table 4.

Device Type 3		
Criteria	During Test	After Test
A & B	May be loss of function (one or more) No unintentional responses	Operate as intended, for equipment type II the communication link may be lost, but shall be recoverable by user No degradation of performance Lost functions shall be self-recoverable

Remark:

The EUT belonged to Type I, class 3.

- performance criteria A for immunity tests with phenomena of a continuous nature;
- performance criteria B for immunity tests with phenomena of a transient nature;
- performance criteria for immunity tests with power interruptions exceeding a certain time are specified in clause 7.2.2, table 6 of EN 301 489-3

Measurement Uncertainty

According to CISPR 16-4-2:2003, measurement uncertainty to immunity test is under consideration.

8.1 Electrostatic Discharge Immunity

Basic Standard :	EN 61000-4-2: 2009
Port :	Enclosure
Required Performance Criterion :	Criteria B (TT & TR)
Level :	± 2.0, ± 4.0, ±8.0 kV (Air Discharge) ±4.0 kV (Contact Discharge) ±4.0 kV (Indirect Contact Discharge)
Temperature :	23.2 °C
Relative Humidity :	58.4 %
No. of Discharge(s) :	Minimum of 10 Discharges per Each Polarity
Time Between Each Discharge :	1 second
Test Mode :	Normal link & EUT Standby
Test Setup :	Table-top
Test of Post-installation :	N/A

8.1.1 Used Test Equipment

Equip. No.	Equipment	Model	Manufacturer
EM077-04	ESD Simulator	NSG437	TESEQ

8.1.2 Block Diagram of Test Setup

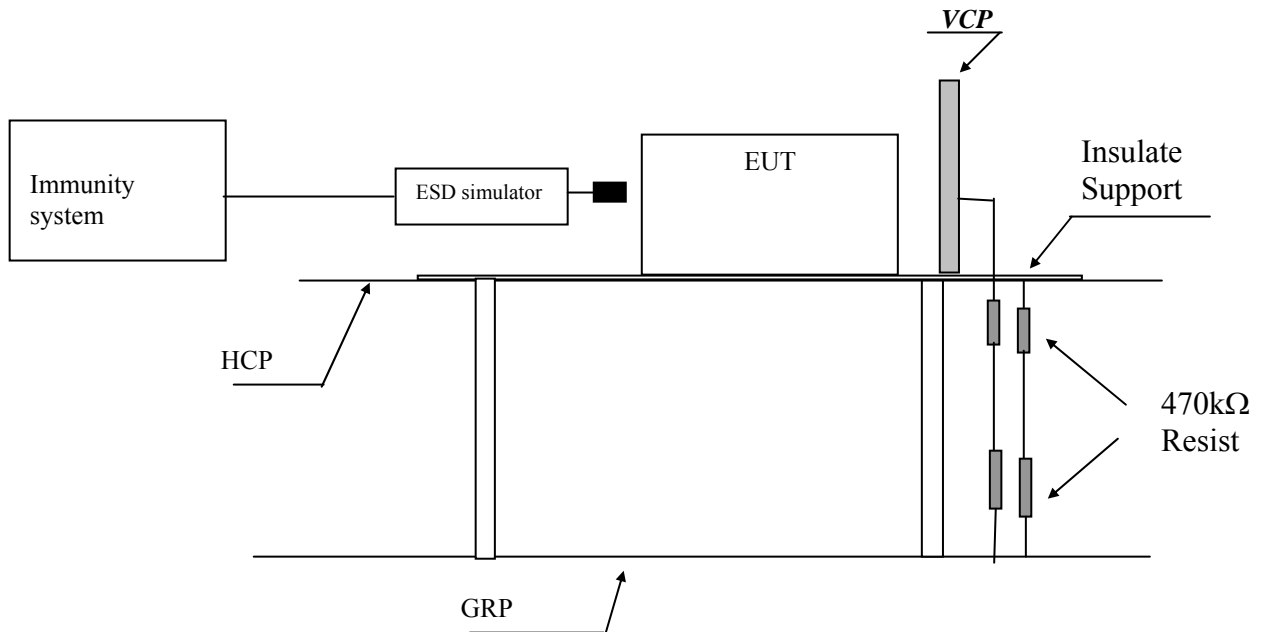

Note: HCP means Horizontal Coupling Plane,
 VCP means Vertical Coupling Plane
 GRP means Ground Reference Plane

8.1.3 Test Setup and Procedure

The EUT was put on a 0.8m high wooden table/0.1m high for floor standing equipment standing on the ground reference plane (GRP) 3m by 2m in size, made by iron 1.0 mm thick.

A horizontal coupling plane (HCP) 1.6m by 0.8m in size was placed on the table, and the EUT with its cables were isolated from the HCP by an insulating support thick than 0.5mm. The VCP 0.5m by 0.5m in size & HCP were constructed from the same material type & thickness as that of the GRP, and connected to the GRP via a 470kΩ resistor at each end.

The distance between EUT and any of the other metallic surface excepted the GRP, HCP & VCP was greater than 1m.

The EUT was arranged and connected according to its functional requirements.

Direct static electricity discharges was applied only to those points and surface which are accessible to personnel during normal usage.

On each preselected points 10 times of each polarity single discharge were applied. The time interval between successive single discharges is at least 1s.

The ESD generator was held perpendicular to the surface to which the discharge is applied. The discharge return cable of the generator was kept at a distance of 0.2m whilst the discharge is being applied. During the contact discharges, the tip of the discharge electrode was touch the EUT before the discharge switch is operated. During the air discharges, the round discharge tip of the discharge electrode was approached as fast as possible to touch the EUT.

Indirect discharge was conducted to objects placed near the EUT, simulated by applying the discharges of the ESD generator to a coupling plane, in the contact discharge mode.

After each discharge, the ESD generator was removed from the EUT, the generator is then retriggered for a new single discharge. For ungrounded product, a grounded carbon fibre brush with bleeder resistors ($2 \times 470 \text{ k}\Omega$) in the grounding cable was used after each discharge to remove remnant electrostatic voltage.

10 times of each polarity single discharge were applied to HCP and VCP. The detail selected points are listed in the following table.

8.1.4 Test Result

Direct Application of ESD

Direct Contact Discharge

Applied Voltage (kV)	No. of Discharge for each point	Result	Discharged Points
4	20	Pass	Accessible metal parts of the EUT Conductive substrate with coating which is not declared to be insulating

Direct Air Discharge

Applied Voltage (kV)	No. of Discharge for each point	Result	Discharged Points
2,4,8	20	Pass	All accessible points where contact discharge cannot be applied such as Displays, Indicators light, Keyboard, Button, Switch, Knob, Air gap, Slots, Hole and so on

Indirect Application of ESD

Horizontal Coupling Plane under the EUT

Applied Voltage (kV)	No. of Discharge for each point	Result	Discharged Point
4	20	Pass	At the front edge of each HCP opposite the centre point of each unit of the EUT

Vertical Coupling Plane beside the EUT

Applied Voltage (kV)	No. of Discharge for each point	Result	Discharged Point
4	20	Pass	The centre of the vertical edge of the coupling plane

8.2 Radiated Electromagnetic Field Immunity

Basic Standard :	EN 61000-4-3: 2006 + A1: 2008 + A2: 2010
Port :	Enclosure
Required Performance Criterion :	Criteria A (CT & CR)
Level :	3.0 V/m (rms)
Test Modulation :	1kHz, 80% AM
Frequency :	80 MHz to 1000 MHz and 1400 MHz to 2700 MHz
Dwell Time :	1s
Frequency Step :	1%
Temperature :	22.0 ⁰ C
Relative Humidity :	50 %
Test Facility :	Full Anechoic Chamber
Antenna Polarization :	Horizontal and Vertical
Type of Antenna :	Log-periodic / Horn
Test Distance :	3m
Test Mode :	Normal link & EUT Standby
Test Setup :	Table-top

8.2.1 Used Test Equipment

Equip. No.	Equipment	Model	Manufacturer
NTC-E-015	Signal Generator	N5181A	Agilent
NTC-E-016	Antenna Log-Periodic	ATR80M6G	CORAD
NTC-E-018	Switch Controller	SC1000	CORAD
NTC-E-021	RF Power Meter	4242	ESE
NTC-E-022	Power Sensor	51011EMC	ESE
NTC-E-019	Power Amplifier	CBA 1G-150	TESEQ
NTC-E-025	Dual Directional Coupler	CPH-274F	TESEQ
NTC-E-013	Horn Antenna	AH-118	COM-Power

8.2.2 Block Diagram of Test Setup

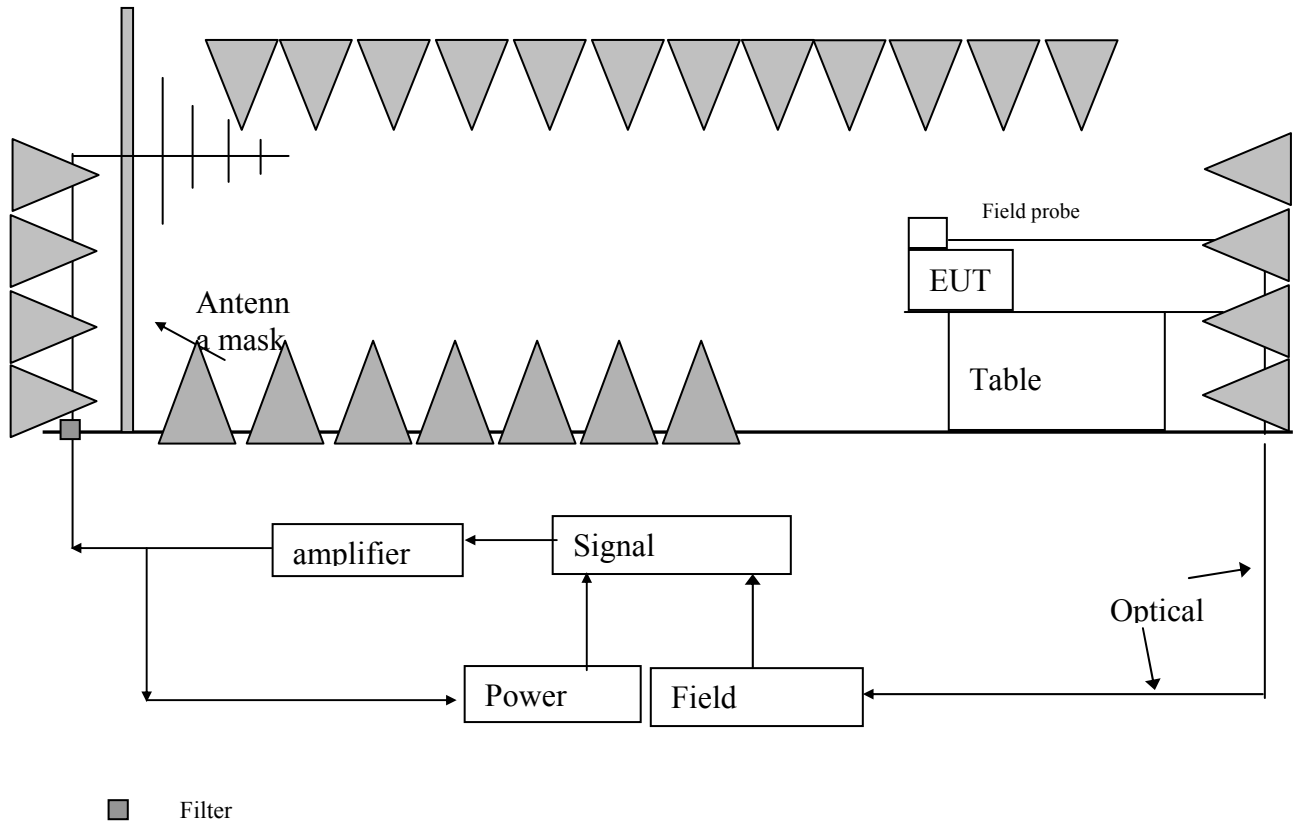

8.2.3 Test Setup and Procedure

The test was conducted in an fully anechoic chamber to maintain a uniform field of sufficient dimensions with respect to the EUT, and also in order to comply with various national and international laws prohibiting interference to radio communications.

The equipment is placed in the test facility on a non-conducting table 0.8m high (for floor standing EUT, is placed on a non-conducting support 0.1m height).

The EUT was placed on the uniform calibrated plane which is 3V/m EM field.

For all ports connected to EUT, manufacturer specified cable type and length was used, for those cables no specification, unshielded cable applied.

Wire is left exposed to the electromagnetic field for a distance of 1m from the EUT.

The EUT was arranged and connected according to its functional requirements

Before testing, the intensity of the established field strength have been checked by placing the field sensor at a calibration grid point, and with the field generating antenna and cables in the same positions as used for the calibration, the forward power needed to give the calibrated field strength was measured.

Spot checks was made at a number of calibration grid points over the frequency range 80MHz to 1000MHz, both polarizations was checked.

After calibration, the EUT is initially placed with one face coincident with the calibration plane.

The frequency range is swept from 80MHz to 1000MHz, with the signal 80% amplitude modulated with a 1 kHz sine-wave, pausing to adjust the r.f. signal level.

The dwell time at each frequency was 3s so as that the EUT to be exercised and be able to respond.

The step size was 1% of the fundamental with linear interpolation between calibrated points. Test was performed with the generating antenna facing each of the four sides of the EUT.

8.2.4 Test Result

Frequency (MHz)	Exposed Side	Field Strength (V/m)	Result
80 to 1000 1400 to 2700	Front	3V/m (r.m.s.)	Pass
80 to 1000 1400 to 2700	Left	3V/m (r.m.s.)	Pass
80 to 1000 1400 to 2700	Rear	3V/m (r.m.s.)	Pass
80 to 1000 1400 to 2700	Right	3V/m (r.m.s.)	Pass

8.3 Electrical Fast Transient/Burst

Basic Standard :	EN 61000-4-4: 2004 +A1: 2010
Port :	A.C. Power Lines
Required Performance Criterion:	Criteria B (TT & TR)
Level:	±0.5, ±1.0kV
Repetition Frequency:	5 kHz
Burst Duration:	300 ms
Test Duration	1 minute per each polarity
Test Mode:	Normal link & EUT Standby
Test Setup:	Table-top
Generator Drive:	Internal
Sequence of Application:	Each One

8.3.1 Used Test Equipment

Equip. No.	Equipment	Model	Manufacturer
EM005-07	EMS test system	Ecompact 4	HAEFELY
EM005-07-01	Capacitive Coupling Clamp	IP4A	HAEFELY

8.3.2 Block Diagram of Test Setup

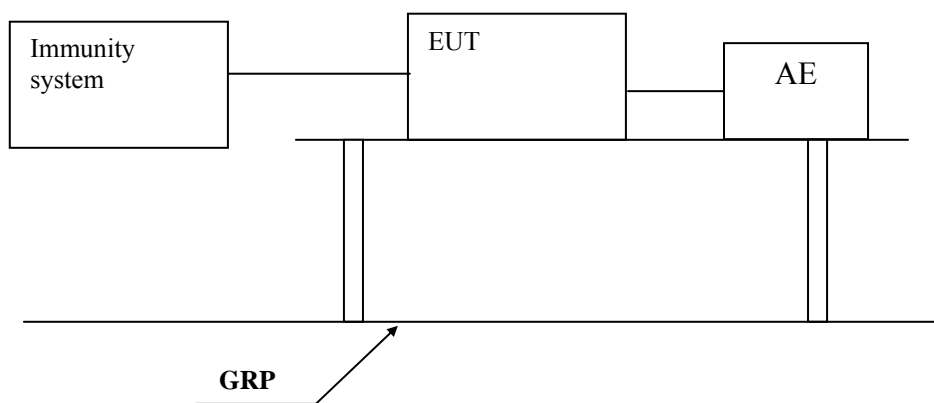

8.3.3 Test Setup and Procedure

The EUT was placed on a 0.1m high wooden table, standing on the ground reference plane 3m by 2m in size, made by steel 1mm thick.

The distance between the EUT and any other of the metallic surface except the GRP is greater than 0.5m.

The mains lead excess than 0.5m is folded to avoid a flat coil and situated at a distance of 0.1m above the ground reference plane to insure the distance between the coupling device and the EUT were 0.5m.

The EUT was arranged and connected to satisfy its functional requirement and supplied by the coupling-decoupling network.

8.3.4 Test Result

Port:	Level	Result
A.C. Power Lines	$\pm 1\text{kV}$	Pass
Telecommunication Lines	$\pm 0.5\text{kV}$	N/A
D.C. Power Lines	$\pm 0.5\text{kV}$	N/A
Signal Lines	$\pm 0.5\text{kV}$	Pass
Control Lines	$\pm 0.5\text{kV}$	N/A

8.4 Surge Immunity

Basic Standard :	EN 61000-4-5: 2006
Port :	A.C. Power Lines
Required Performance Criterion :	Criteria B (TT & TR)
Level :	±1kV Live to Neutral
Generator Impedance :	2 ohm
Repetition Rate :	1 minute
Test Mode :	Normal link & EUT Standby
Test Setup :	Table-top
Surge Generator Trigger :	Internal
Phase Angle :	0°, 90°, 180°, 270°

8.4.1 Used Test Equipment

Equip. No.	Equipment	Model	Manufacturer
EM005-09	Surge/DIP Generator	NSG3040	TESEQ

8.4.2 Block Diagram of Test Setup

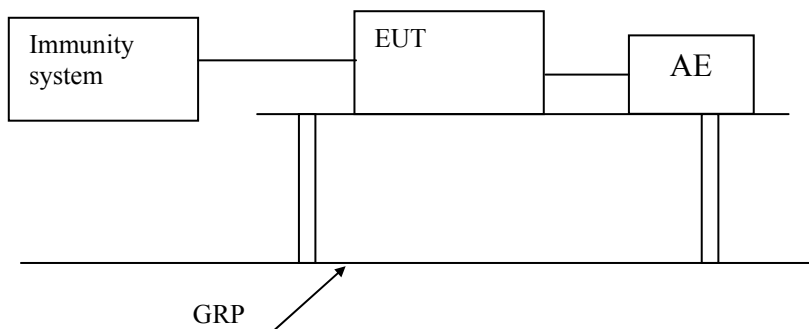

8.4.3 Test Setup and Procedure

The surge is to be applied to the EUT power supply terminals via the capacitive coupling network.

Decoupling networks are required in order to avoid possible adverse effects on equipment not under test that may be powered by the same lines and to provide sufficient decoupling impedance to the surge wave so that the specified wave may be developed on the lines under test.

The EUT was arranged and connected according to its functional requirements



The EUT was placed on a 0.1m high wooden support above the GRP, supplied by the coupling-decoupling network, and arranged and connected to satisfy its functional requirement and the power cord between the EUT and the coupling/decoupling network was less than 2 meters.

Surge is applied to the EUT power supply terminals.

8.4.4 Test Result

Level		Result
Between Phase And Phase:	1kV	N/A
Between Phase And Neutral:	1kV	Pass
Between Phase And Earth:	2kV	N/A
Between Neutral And Earth:	2kV	N/A

8.5 Injected Current

Basic Standard :	EN 61000-4-6: 2009
Port :	A.C. Power Lines
Required Performance Criterion :	Criteria A (CT & CR)
Level :	3.0V (rms)
Test Modulation :	1 kHz, 80% AM
Frequency :	0.15 MHz to 80 MHz
Dwell Time :	1s
Frequency Step :	1%
Temperature :	23.2 °C
Relative Humidity :	58.4 %
Test Mode :	Normal link & EUT Standby
Test Setup :	Table-top
Equipment Under Test (EUT):	Single Unit

8.5.1 Used Test Equipment

Equip. No.	Equipment	Model	Manufacturer
EM003-01	Conducted Disturbance Generator	CDG_1020	Dr.Hubert GmbH

8.5.2 Block Diagram of Test Setup

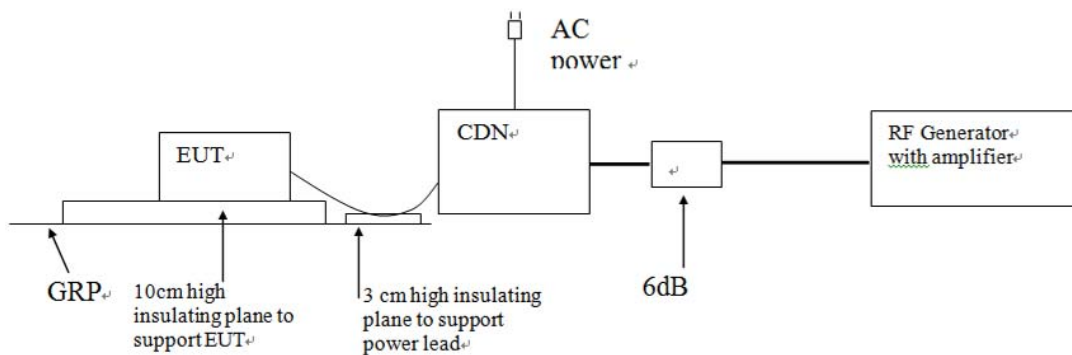

8.5.3 Test Setup and Procedure

The EUT was placed on an insulating support of 0.1m height above a ground reference Plane, arranged and connected to satisfy its functional requirement.

All relevant cables were provided with the appropriate coupling and decoupling devices at a distance between 0.1m and 0.3m from the projected geometry of the EUT on an insulating support of 0.03m height above the ground reference plane.

Test voltage was verified before each testing though power meter combined in the RF generator with AMP.

Dwell time was set to 3s and step was set as 1% to keep sufficient response time for EUT. The frequency from 0.15MHz to 230MHz was checked.

8.5.4 Test Result

Port:	Frequency (MHz)	Level	Result
A.C. Power Lines	0.15 to 230	3V (r.m.s.)	Pass
Telecommunication Lines	0.15 to 230	3V (r.m.s.)	N/A
D.C. Power Lines	0.15 to 230	3V (r.m.s.)	N/A
Signal Lines	0.15 to 230	3V (r.m.s.)	Pass
Control Lines	0.15 to 230	3V (r.m.s.)	N/A

8.6 Voltage Dips and Interruptions

Basic Standard :	EN 61000-4-11: 2004
Port :	A.C. Power Lines
Required Performance Criterion:	Criteria A: 0 % U_T for 0.5 per and 0% U_T for 1per and 70 % U_T for 25per Criteria B: 0 % U_T for 250per (TT & TR)
Level:	0 % U_T for 0.5 per
	0% U_T for 1per
	0 % U_T for 250per
	70 % U_T for 25per
No. of Dips/Interruptions	3
Test Mode:	Normal link & EUT Standby
Test Setup:	Table-top

8.6.1 Used Test Equipment

Equip. No.	Equipment	Model	Manufacturer
EM005-07	EMS test system	Ecompact 4	HAEFELY

8.6.2 Block Diagram of Test Setup

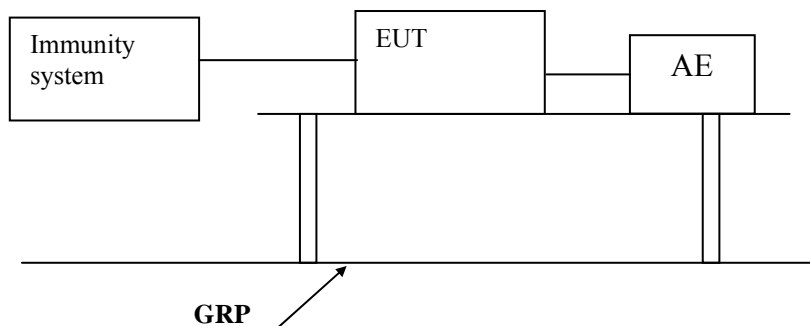

8.6.3 Test Setup and Procedure

The EUT was placed on an insulating support of 0.8m height, standing on a ground reference plane, and arranged and connected to satisfy its functional requirement

The test was performed with the EUT connected to the test generator with the shortest power supply cable as specified by the EUT manufacturer.

The EUT was tested for each selected combination of test level and duration with a sequence of three dips/interruptions with intervals of 10 s minimum. Each representative mode of operation was tested.

8.6.4 Test Result

Test Condition		Result
Test Level in %U _T	Duration(s)	50 Hz
0	0.01	Pass
0	0.02	Pass
0	5	Pass
70	0.5	Pass

Remark: U_T is the rated voltage for the equipment.

9 Appendix I - Photos of test setup

Conducted Emission



ESD Immunity

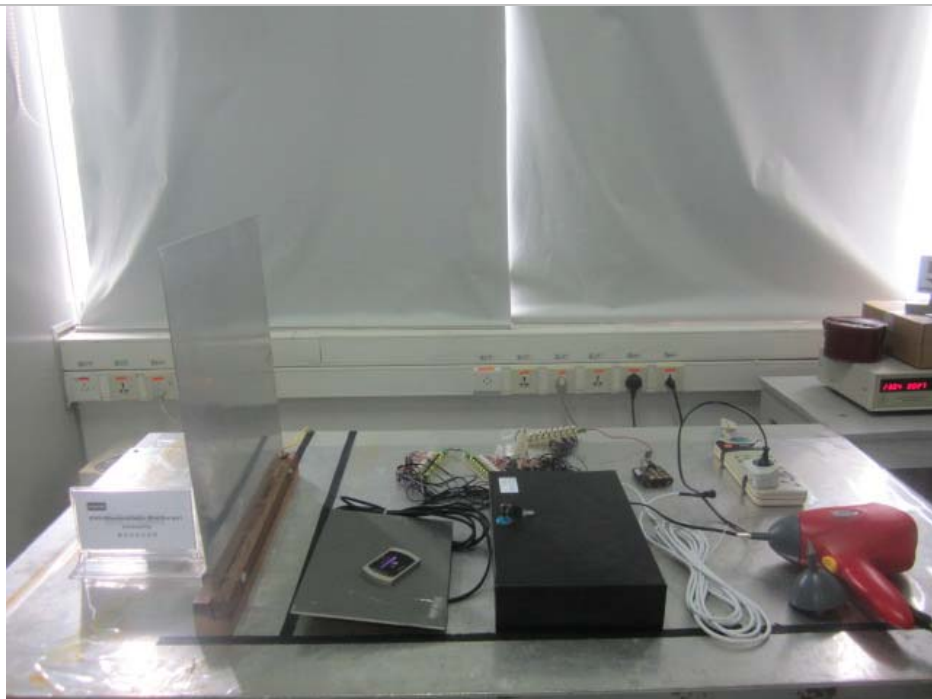

Conducted Immunity



EFT/DIP Immunity



Surge Immunity



Radiated Immunity

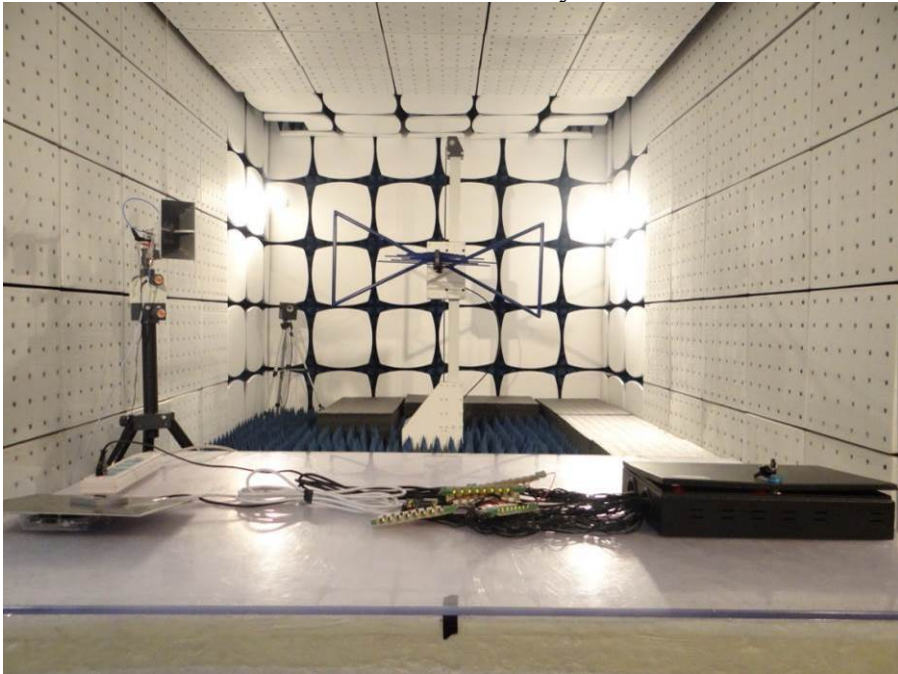

10 Appendix II - Photos of EUT







